

Q. No. 1 – 5 Carry One Mark Each

1. “India is a country of rich heritage and cultural diversity.” Which one of the following facts best supports the claim made in the above sentence?
- (A) India is a union of 28 states and 7 union territories.
 (B) India has a population of over 1.1 billion.
 (C) India is home to 22 official languages and thousands of dialects.
 (D) The Indian cricket team draws players from over ten states.

Answer: C

Exp: Diversity is shown in terms of difference language

2. The value of one U.S. dollar is 65 Indian Rupees today, compared to 60 last year. The Indian Rupee has _____.
- (A) Depressed (B) Depreciated (C) Appreciated (D) Stabilized

Answer: B

3. 'Advice' is _____.
- (A) a verb (B) a noun
 (C) an adjective (D) both a verb and a noun

Answer: B

4. The next term in the series 81, 54, 36, 24 ... is _____

Answer: 16

Exp: $81 - 54 = 27; 27 \times \frac{2}{3} = 18$

$54 - 36 = 18; 18 \times \frac{2}{3} = 12$

$36 - 24 = 12; 12 \times \frac{2}{3} = 8$

$\therefore 24 - 8 = 16$



5. In which of the following options will the expression $P < M$ be definitely true?
- (A) $M < R > P > S$ (B) $M > S < P < F$
 (C) $Q < M < F = P$ (D) $P = A < R < M$

Answer: D

Q. No. 6 – 10 Carry Two Marks Each

6. Find the next term in the sequence: 7G, 11K, 13M, _____
- (A) 15Q (B) 17Q (C) 15P (D) 17P

Answer: B

7. The multi-level hierarchical pie chart shows the population of animals in a reserve forest. The correct conclusions from this information are:

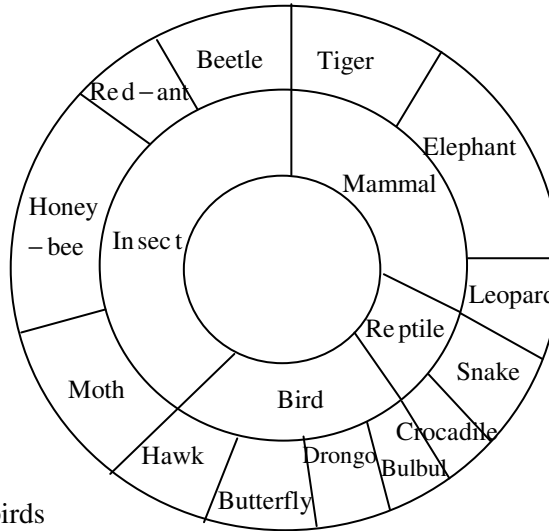

- (i) Butterflies are birds
 (ii) There are more tigers in this forest than red ants
 (iii) All reptiles in this forest are either snakes or crocodiles
 (iv) Elephants are the largest mammals in this forest
 (A) (i) and (ii) only
 (B) (i), (ii), (iii) and (iv)
 (C) (i), (iii) and (iv) only
 (D) (i), (ii) and (iii) only

Answer: D

Exp: It is not mentioned that elephant is the largest animal

8. A man can row at 8 km per hour in still water. If it takes him thrice as long to row upstream, as to row downstream, then find the stream velocity in km per hour.

Answer: 4

Exp: Speed of man=8; Left distance =d

$$\text{Time taken} = \frac{d}{8}$$

Upstream:

Speed of stream=s

$$\Rightarrow \text{speed upstream} = S' = (8 - s)$$

$$t' = \left(\frac{d}{8 - s} \right)$$

Downstream:

$$\text{Given speed downstream} = t'' = \frac{d}{8 + s}$$

$$\Rightarrow 3t' = t'' \Rightarrow \frac{3d}{8 - s} = \frac{d}{8 + s}$$

$$\Rightarrow \frac{3d}{8 - s} = \frac{d}{8 + s} \Rightarrow s = 4 \text{ km/hr}$$

9. A firm producing air purifiers sold 200 units in 2012. The following pie chart presents the share of raw material, labour, energy, plant & machinery, and transportation costs in the total manufacturing cost of the firm in 2012. The expenditure on labour in 2012 is Rs. 4,50,000. In 2013, the raw material expenses increased by 30% and all other expenses increased by 20%. If the company registered a profit of Rs. 10 lakhs in 2012, at what price (in Rs.) was each air purifier sold?

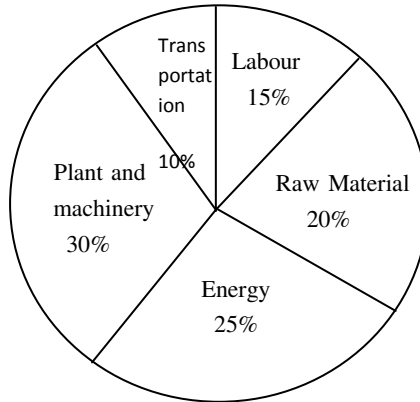

Answer: 20,000

Exp: Total expenditure = $\frac{15}{100} x = 4,50,000$

$x = 3 \times 10^6$

Profit = 10 lakhs

So, total selling price = 40,00,000 ... (1)

Total purifiers = 200 ... (2)

S.P of each purifier = $(1)/(2) = 20,000$

10. A batch of one hundred bulbs is inspected by testing four randomly chosen bulbs. The batch is rejected if even one of the bulbs is defective. A batch typically has five defective bulbs. The probability that the current batch is accepted is _____

Answer: 0.8145

Exp: Probability for one bulb to be non defective is $\frac{95}{100}$

\therefore Probabilities that none of the bulbs is defectives $\left(\frac{95}{100}\right)^4 = 0.8145$

Q. No. 1 – 25 Carry One Mark Each

1. Consider a 3×3 real symmetric matrix S such that two of its eigen values are $a \neq 0, b \neq 0$

with respective eigenvectors $\begin{bmatrix} x_1 \\ x_2 \\ x_3 \end{bmatrix}, \begin{bmatrix} y_1 \\ y_2 \\ y_3 \end{bmatrix}$. If $a \neq b$ then $x_1y_1 + x_2y_2 + x_3y_3$ equals

- (A) a (B) b (C) ab (D) 0

Answer: (D)

Exp: We know that the Eigen vectors corresponding to distinct Eigen values of real symmetric matrix are orthogonal.

$$\begin{bmatrix} x_1 \\ x_2 \\ x_3 \end{bmatrix} \begin{bmatrix} y_1 \\ y_2 \\ y_3 \end{bmatrix} = x_1y_1 + x_2y_2 + x_3y_3 = 0$$

2. If a function is continuous at a point,
 (A) The limit of the function may not exist at the point
 (B) The function must be derivable at the point
 (C) The limit of the function at the point tends to infinity
 (D) The limit must exist at the point and the value of limit should be same as the value of the function at that point

Answer: (D)

Exp: We know that $f(x)$ is continuous at $x=a$, if $\lim_{x \rightarrow a} f(x)$ exists and equal to $f(a)$

3. Divergence of the vector field $x^2z\hat{i} + xy\hat{j} - yz^2\hat{k}$ at $(1, -1, 1)$ is
 (A) 0 (B) 3 (C) 5 (D) 6

Answer: (C)

Exp: Given $\vec{F} = x^2z\hat{i} + xy\hat{j} - yz^2\hat{k}$
 $\text{div } \vec{F} = \nabla \cdot \vec{F}$
 $= \frac{\partial}{\partial x}(x^2z) + \frac{\partial}{\partial y}(xy) + \frac{\partial}{\partial z}(-yz^2)$
 $= 2xz + x - 2yz$
 $\text{div } \vec{F} \text{ at } (1, -1, 1) = 2+1+2 = 5$

4. A group consists of equal number of men and women. Of this group 20% of the men and 50% of the women are unemployed. If a person is selected at random from this group, the probability of the selected person being employed is _____

Answer: 0.64 to 0.66

Exp: Let $M \rightarrow$ men
 $W \rightarrow$ women
 $E \rightarrow$ employed
 $U \rightarrow$ unemployed

Given $P(M) = 0.5$
 $P(W) = 0.5$
 $P\left(\frac{U}{M}\right) = 0.20$
 $P\left(\frac{U}{W}\right) = 0.50$

By Total probability,

$$P(U) = P(M) P\left(\frac{U}{M}\right) + P(W) P\left(\frac{U}{W}\right)$$

$$= 0.5 \times 0.20 + 0.5 \times 0.50 = 0.35$$

Required probability = $P(E) = 1 - P(U) = 1 - 0.35 = 0.65$

5. The definite integral $\int_1^3 \frac{1}{x} dx$ is evaluated using Trapezoidal rule with a step size of 1. The correct answer is _____

Answer: 1.1 to 1.2

Exp: Given, $\int_1^3 \frac{1}{x} dx$

$h = \text{step size} = 1$

$n = \text{no. of sub intervals} = \frac{3-1}{1} = 2$

Let $y = \frac{1}{x}$

x	1	2	3
$y = \frac{1}{x}$	1	$\frac{1}{2}$	$\frac{1}{3}$

By trapezoidal rule

$$\int_{x_0}^{x_n} f(x) dx = \frac{h}{2} [(y_0 + y_n) + 2(y_1 + \dots + y_{n-1})]$$

$$\int_1^3 \frac{1}{x} dx = \frac{1}{2} \left[\left(1 + \frac{1}{3} \right) + 2 \left(\frac{1}{2} \right) \right] = \frac{1}{2} \left[\frac{4}{3} + 1 \right] = \frac{1}{2} \times \frac{7}{3} = 1.1667$$

6. A rotating steel shaft is supported at the ends. It is subjected to a point load at the centre. The maximum bending stress developed is 100 MPa. If the yield, ultimate and corrected endurance strength of the shaft material is 300 MPa, 500 MPa and 200 MPa, respectively, then the factor of safety for the shaft is _____

Answer: 1.9 to 2.1

Exp: $\sigma = \min \text{ of } \frac{(S_{yt}, S_{ut}, S_e)}{F_o S}$

$$FOS = \frac{200}{100} = 2.$$

7. Two solid circular shafts of radii R_1 and R_2 are subjected to same torque. The maximum shear stresses developed in the two shafts are τ_1 and τ_2 . If $R_1/R_2=2$, then τ_2/τ_1 is _____

Answer: 7.9 to 8.1

Exp: $\tau = \frac{16T}{\pi d^3}$

$$\Rightarrow \frac{\tau_2}{\tau_1} = \left(\frac{d_1}{d_2}\right)^3 = \left(\frac{R_1}{R_2}\right)^3 = 2^3 = 8.$$

8. Consider a single degree-of-freedom system with viscous damping excited by a harmonic force. At resonance, the phase angle (in degree) of the displacement with respect to the exciting force is

(A) 0 (B) 45 (C) 90 (D) 135

Answer: (C)

9. A mass m_1 of 100 kg travelling with a uniform velocity of 5 m/s along a line collides with a stationary mass m_2 of 1000 kg. After the collision, both the masses travel together with the same velocity. The coefficient of restitution is

(A) 0.6 (B) 0.1 (C) 0.01 (D) 0

Answer: (D)

Exp: Coefficient of Restitution = $\frac{\text{Velocity of separation}}{\text{Velocity of approach}}$

$$= \frac{V_2 - V_1}{u_1 - u_2} = \frac{V - V}{5 - 0} = 0$$

$\therefore V_2 = V_1 = V$ final velocity is same.

10. Which one of following is **NOT** correct?
- (A) Intermediate principal stress is ignored when applying the maximum principal stress theory
 - (B) The maximum shear stress theory gives the most accurate results amongst all the failure theories
 - (C) As per the maximum strain energy theory, failure occurs when the strain energy per unit volume exceeds a critical value
 - (D) As per the maximum distortion energy theory, failure occurs when the distortion energy per unit volume exceeds a critical value

Answer: (B)

11. Gear 2 rotates at 1200 rpm in counter clockwise direction and engages with Gear 3. Gear 3 and Gear 4 are mounted on the same shaft. Gear 5 engages with Gear 4. The numbers of teeth on Gears 2, 3, 4 and 5 are 20, 40, 15 and 30, respectively. The angular speed of Gear 5 is

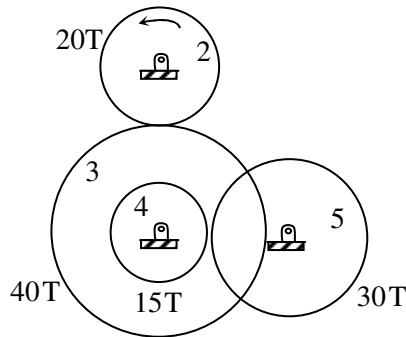

- (A) 300 rpm counter clockwise (B) 300 rpm clockwise
(C) 4800 rpm counter clockwise (D) 4800 rpm clockwise

Answer: (A)

Exp:
$$\frac{N_5}{N_2} = \frac{T_2 \times T_4}{T_3 \times T_5} = \frac{20 \times 15}{40 \times 30}$$

$$\Rightarrow N_5 = 1200 \times 0.25 = 300 \text{ rpm ccw.}$$

12. Consider a long cylindrical tube of inner and outer radii, r_i and r_o , respectively, length, L and thermal conductivity, k . Its inner and outer surfaces are maintained at T_i and T_o , respectively ($T_i > T_o$). Assuming one-dimensional steady state heat conduction in the radial direction, the thermal resistance in the wall of the tube is

- (A) $\frac{1}{2\pi kL} \ln\left(\frac{r_i}{r_o}\right)$ (B) $\frac{1}{2\pi r_i k}$ (C) $\frac{1}{2\pi r_i k} \ln\left(\frac{r_o}{r_i}\right)$ (D) $\frac{1}{4\pi r_i k} \ln\left(\frac{r_o}{r_i}\right)$

Answer: (C)

Exp: $A_r = 2\pi rL$

From Fourier's Law

$$q_r = -kA_r \frac{dT}{dr}$$

$$q_r = -2\pi k r L \frac{dT}{dr}$$

Boundary conditions :

$$T = T_i \text{ at } r = r_i$$

$$T = T_o \text{ at } r = r_o$$

$$q = \frac{2\pi k L (T_i - T_o)}{\ln(r_o/r_i)}$$

$$= \frac{T_i - T_o}{\frac{\ln(r_o/r_i)}{2\pi k L}} = \frac{T_i - T_o}{R_{th}}$$

$$R_{th} = \frac{\ln(r_o/r_i)}{2\pi k L}$$

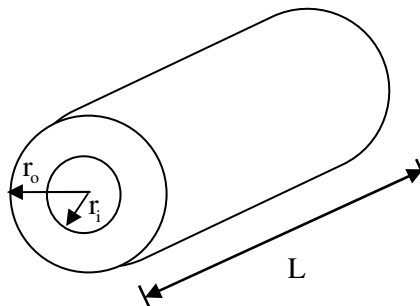

13. Which one of the following pairs of equations describes an irreversible heat engine?

- (A) $\oint \delta Q > 0$ and $\oint \frac{\delta Q}{T} < 0$ (B) $\oint \delta Q < 0$ and $\oint \frac{\delta Q}{T} < 0$
 (C) $\oint \delta Q > 0$ and $\oint \frac{\delta Q}{T} > 0$ (D) $\oint \delta Q < 0$ and $\oint \frac{\delta Q}{T} > 0$

Answer: (A)

Exp: For clausius theorem, $\oint \frac{\delta Q}{T} < 0$ (for irreversible Heat engine).

14. Consider the turbulent flow of a fluid through a circular pipe of diameter, D . Identify the correct pair of statements.

- I. The fluid is well-mixed
 II. The fluid is unmixed
 III. $Re_D < 2300$
 IV. $Re_D > 2300$

- (A) I, III (B) II, IV (C) II, III (D) I, IV

Answer: (D)

Exp: $Re_D > 2300$ means it is a turbulent flow. In turbulent flow, the fluid is well mixed. The fluid is unmixed, for a very-low Reynolds number laminar flow.

15. For a gas turbine power plant, identify the correct pair of statements.

- P. Smaller in size compared to steam power plant for same power output
 Starts quickly compared to steam power plant
 R. Works on the principle of Rankine cycle
 S. Good compatibility with solid fuel

- (A) P, Q (B) R, S (C) Q, R (D) P, S

Answer: (A)

Exp: Steam power plants are bulky due to presence of boiler and condenser. Gas turbines are compact, as compressors and turbines are coupled on a common shaft. In steam power plants, boiler takes lot of time to get started, as compared to Gas Turbines.

16. A source at a temperature of 500 K provides 1000 kJ of heat. The temperature of environment is 27°C. The maximum useful work (in kJ) that can be obtained from the heat source is _____

Answer: 399 to 401

Exp: $\eta = \frac{W_{net}}{Q_{in}} = 1 - \frac{T_{sink}}{T_{source}}$
 $1 - \frac{300}{500} = \frac{W_{net}}{1000}$
 $W_{net} = 1000 \times 0.4$
 $= 400 \text{ kJ.}$

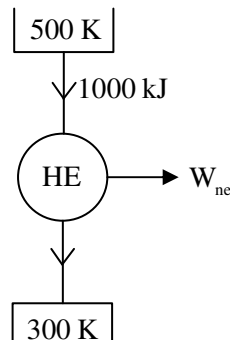

17. A sample of moist air at a total pressure of 85 KPa has a dry bulb temperature of 30°C (saturation vapour pressure of water = 4.24 KPa). If the air sample has a relative humidity of 65%, the absolute humidity (in gram) of water vapour per kg of dry air is _____

Answer: 19 to 22

Exp: $P_T = 85 \text{ KPa}$, $\text{DBT} = 30^\circ\text{C}$

$P_{w,s} = 4.24 \text{ KPa}$, $\text{RH} = 65\%$

$$\therefore P_w = P_{w,s} \times \frac{\text{RH}}{100} = 4.24 \times 0.65 = 2.756 \text{ KPa}$$

$$\text{now } \omega = 622 \frac{P_w}{P_T} = \text{gm (of water) / mg. d. a}$$

$$\therefore \omega = \frac{622 \times 2.756}{85} = 20.17 \text{ gm (of water) / mg. d. a}$$

18. The process utilizing mainly thermal energy for removing material is
 (A) Ultrasonic Machining (B) Electrochemical Machining
 (C) Abrasive Jet Machining (D) Laser Beam Machining

Answer: (D)

19. The actual sales of a product in different months of a particular year are given below:

September	October	November	December	January	February
180	280	250	190	240	?

The forecast of the sales, using the 4-month moving average method, for the month of February is _____

Answer: 239 to 241

Exp: Number of periods = 4, then the past 4 months average sales is fore cast for next 4 months.

$$\text{So, } \frac{280 + 250 + 190 + 240}{4} = 240.$$

20. A straight turning operation is carried out using a single point cutting tool on an AISI 1020 steel rod. The feed is 0.2 mm/rev and the depth of cut is 0.5 mm. The tool has a side cutting edge angle of 60°. The uncut chip thickness (in mm) is _____

Answer: 0.08 to 0.12

Exp: $t_1 = f \cos \theta$

$$= 0.2 \times \cos 60$$

$$t_1 = 0.1 \text{ mm}$$

where $t_1 = \text{uncut chip thickness}$

21. A minimal spanning tree in network flow models involves

- (A) All the nodes with cycle/loop allowed
 (B) All the nodes with cycle/loop not allowed
 (C) Shortest path between start and end nodes
 (D) All the nodes with directed arcs

Answer: (B)

Exp: A path forms a loop or cycle if it connects a node itself. A spanning tree links all the nodes of network with no loops allowed.

22. Match the casting defects (Group A) with the probable causes (Group B):

Group A	Group B
(p) Hot tears	1: Improper fusion of two streams of liquid metal
(q) Shrinkage	2: Low permeability of the sand mould
(r) Blow holes	3: Volumetric contraction both in liquid and solid stage
(s) Cold Shut	4: Differential cooling rate

(A) P-1, Q-3, R-2, S-4

(B) P-4, Q-3, R-2, S-1

(C) P-3, Q-4, R-2, S-1

(D) P-1, Q-2, R-4, S-3

Answer: (B)

23. Cutting tool is much harder than the workpiece. Yet the tool wears out during the tool-work interaction, because

(A) extra hardness is imparted to the workpiece due to coolant used

(B) oxide layers on the workpiece surface impart extra hardness to it

(C) extra hardness is imparted to the workpiece due to severe rate of strain

(D) vibration is induced in the machine tool

Answer: (C)

24. The stress-strain curve for mild steel is shown in the figure given below. Choose the correct option referring to both figure and table.

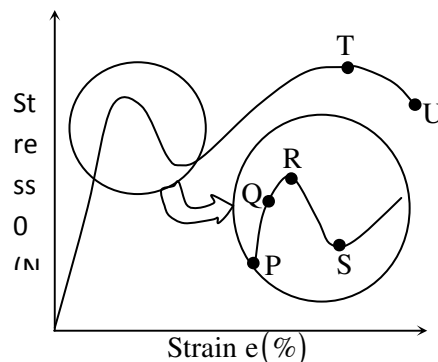

Point on the graph	Description of the point
P	1. Upper Yield Point
Q	2. Ultimate Tensile Strength
R	3. Proportionality Limit
S	4. Elastic Limit
T	5. Lower Yield Point
U	6. Failure

- (A) P-1, Q-2, R-3, S-4, T-5, U-6 (B) P-3, Q-1, R-4, S-2, T-6, U-5
 (C) P-3, Q-4, R-1, S-5, T-2, U-6 (D) P-4, Q-1, R-5, S-2, T-3, U-6

Answer: (C)

25. The hot tearing in a metal casting is due to
 (A) high fluidity
 (B) high melt temperature
 (C) wide range of solidification temperature
 (D) low coefficient of thermal expansion

Answer: (C)

Q. No. 26 – 55 Carry Two Marks Each

26. An analytic function of a complex variable $z = x + iy$ is expressed as $f(z) = w(x, y) + iv(x, y)$, where $i = \sqrt{-1}$. If $u(x, y) = x^2 - y^2$, then expression for $v(x, y)$ in terms of x, y and a general constant c would be

- (A) $xy + c$ (B) $\frac{x^2 + y^2}{2} + c$ (C) $2xy + c$ (D) $\frac{(x - y)^2}{2} + c$

Answer: (C)

Exp: Given $f(z) = u(x, y) + iv(x, y)$ is analytic and $u = x^2 - y^2$

We know that if $f(z) = u + iv$ is analytic then C-R equations will be satisfied.

$$\text{ie., } \frac{\partial u}{\partial x} = \frac{\partial v}{\partial y} \quad \text{and} \quad \frac{\partial u}{\partial y} = -\frac{\partial v}{\partial x}$$

$\therefore v = 2xy + c$ is correct answer

27. Consider two solutions $x_1(t) = x_1(t)$ and $x_2(t) = x_2(t)$ of the differential equation

$$\frac{d^2x(t)}{dt^2} + x(t) = 0, t > 0, \text{ Such that } x_1(0) = 1, 1, \left. \frac{dx_1(t)}{dt} \right|_{t=0} = 0, x_2(0) = 0, \left. \frac{dx_2(t)}{dt} \right|_{t=0} = 1.$$

$$\text{The Wronskian } W(t) = \begin{vmatrix} x_1(t) & x_2(t) \\ \frac{dx_1(t)}{dt} & \frac{dx_2(t)}{dt} \end{vmatrix} \text{ at } t = \frac{\pi}{2} \text{ is}$$

- (A) 1 (B) -1 (C) 0 (D) $\frac{\pi}{2}$

Answer: (A)

Exp: Given Differential equation is

$$\frac{d^2x(t)}{dt^2} + x(t) = 0$$

Auxiliary equation is $m^2 + 1 = 0$

$$m = 0 \pm i$$

Complementary y solution is

$$x_c = c_1 \cos t + c_2 \sin t$$

Particular solution $x_p = 0$

∴ General solution $x = c_1 \cos t + c_2 \sin t$

$$\text{Let } x_1(t) = \cos t \quad x_2(t) = \sin t$$

$$\text{clearly } x_1(0) = 1 \quad \frac{dx_1}{dt} = 0 \quad \text{and } x_2(0) = 0, \quad \frac{dx_2}{dt} = 1$$

$$W = \begin{vmatrix} x_1(t) & x_2(t) \\ \frac{dx_1}{dt} & \frac{dx_2}{dt} \end{vmatrix}_{t=\pi/2} = \begin{vmatrix} \cos t & \sin t \\ -\sin t & \cos t \end{vmatrix}_{t=\pi/2} = \cos^2 t + \sin^2 t = 1$$

28 A machine produces 0, 1 or 2 defective pieces in a day with associated probability of 1/6, 2/3 and 1/6, respectively. The mean value and the variance of the number of defective pieces produced by the machine in a day, respectively, are

- (A) 1 and 1/3 (B) 1/3 and 1 (C) 1 and 4/3 (D) 1/3 and 4/3

Answer: (A)

Exp: Let 'x' be no. of defective pieces.

$$x \quad 0 \quad 1 \quad 2$$

$$P(x) \quad \frac{1}{6} \quad \frac{2}{3} \quad \frac{1}{6}$$

$$\text{mean } (\mu) = E(x) = \sum x P(x)$$

$$= \left(0 \times \frac{1}{6}\right) + \left(1 \times \frac{1}{3}\right) + \left(2 \times \frac{1}{6}\right)$$

$$= 0 + \frac{2}{3} + \frac{1}{3} = 1$$

$$E(x^2) = \sum x^2 P(x)$$

$$= \left(0 \times \frac{1}{6}\right) + \left(1 \times \frac{2}{3}\right) + \left(4 \times \frac{1}{6}\right)$$

$$= 0 + \frac{2}{3} + \frac{2}{3} = \frac{4}{3}$$

$$\text{Variance } V(x) = E(x^2) - \{E(x)\}^2$$

$$= \frac{4}{3} - 1 = \frac{1}{3}$$

29. The real root of the equation $5x - 2\cos x - 1 = 0$ (up to two decimal accuracy) is _____

Answer: 0.53 to 0.56

Exp: Let $f(x) = 5x - 2\cos x - 1$

$$\Rightarrow f'(x) = 5 + 2\sin x$$

$$f(0) = -3; \quad f(1) = 2.9$$

By intermediate value theorem roots lie between 0 and 1.

$$\text{Let } x_0 = 1 \text{ rad} = 57.32^\circ$$

By Newton Raphson method,

$$x_{n+1} = x_n - \frac{f(x_n)}{f'(x_n)}$$

$$\Rightarrow x_{n+1} = \frac{2x_n \sin x_n + 2\cos x_n + 1}{5 + 2\sin x_n}$$

$$\Rightarrow x_1 = 0.5632$$

$$\Rightarrow x_2 = 0.5425$$

$$\Rightarrow x_3 = 0.5424$$

30. A drum brake is shown in the figure. The drum is rotating in anticlockwise direction. The coefficient of friction between drum and shoe is 0.2. The dimensions shown in the figure are in mm. The braking torque (in N.m) for the brake shoe is _____

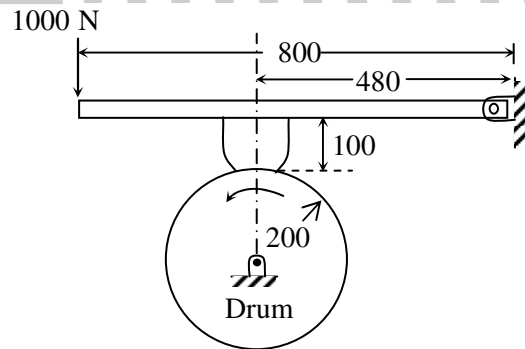

Answer: 63 to 65

Exp: Taking moments about pin joint ($\sum M$)

$$\Rightarrow 1000 \times 0.8 = R_N \times 0.48 + \mu R_N \times 0.1$$

$$\Rightarrow R_N = \frac{800}{0.5}$$

$$= 1600$$

$$T_B = \mu R_N \times r$$

$$= 0.2 \times 1600 \times \frac{200}{1000} = 64 \text{ N-m.}$$

31. A body of mass (M) 10 kg is initially stationary on a 45° inclined plane as shown in figure. The coefficient of dynamic friction between the body and the plane is 0.5. The body slides down the plane and attains a velocity of 20 m/s. The distance travelled (in meter) by the body along the plane is _____

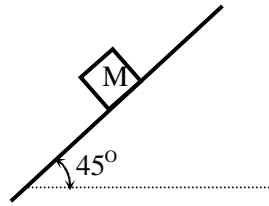

Answer: 56 to 59

Exp: FBD of block

Net force = ma

$$mg \sin 45 - \mu mg \cos 45 = ma$$

$$\Rightarrow a = 3.46 \text{ m/s}^2$$

$$\Rightarrow V^2 - u^2 = 2as$$

$$\Rightarrow S = \frac{V^2}{2a} = \frac{20^2}{2 \times 3.46} = 57.8 \text{ m.}$$

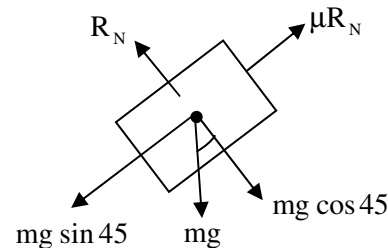

32. Consider a simply supported beam of length, $50h$, with a rectangular cross-section of depth, h , and width, $2h$. The beam carries a vertical point load, P , at its mid-point. The ratio of the maximum shear stress to the maximum bending stress in the beam is
(A) 0.02 (B) 0.10 (C) 0.05 (D) 0.01

Answer: (D)

Exp: Given, $b = 2h$, $d = h$, $l = 50h$, force = p

$$\text{shear stress} = \frac{3}{2} \times \frac{\text{shear force}}{d \times b}$$

$$= \frac{3}{2} \times \frac{p}{h \times 2h} = \frac{3p}{4h^2}$$

$$\text{Bending stress} = \frac{M}{I} \times y$$

$$= \frac{p \times l/2}{\frac{bd^3}{12}} \times \frac{d}{2}$$

$$= \frac{p \times 50h/2 \times \frac{h}{2}}{\frac{(2h)h^3}{12}} = \frac{\frac{25}{2} \times 6ph^2}{h^2} = \frac{75p}{h^2}$$

$$\frac{\text{Shear stress}}{\text{Bending stress}} = \frac{\frac{3p}{4h^2}}{\frac{75p}{h^2}} = \frac{3}{4 \times 75} = 0.01.$$

33. The damping ratio of a single degree of freedom spring-mass-damper system with mass of 1 kg, stiffness 100 N/m and viscous damping coefficient of 25 N.s/m is _____

Answer: 1.24 to 1.26

Exp: Damping ratio

$$\begin{aligned} (\xi) &= \frac{C}{C_c} = \frac{C}{2\sqrt{km}} \\ &= \frac{25}{2\sqrt{1 \times 100}} = \frac{25}{20} = 1.25 \end{aligned}$$

34. An annular disc has a mass m , inner radius R and outer radius $2R$. The disc rolls on a flat surface without slipping. If the velocity of the centre of mass is v , the kinetic energy of the disc is

(A) $\frac{9}{16}mv^2$ (B) $\frac{11}{16}mv^2$ (C) $\frac{13}{16}mv^2$ (D) $\frac{15}{16}mv^2$

Answer: (C)

Exp: $\therefore I = \frac{1}{2}m(2R)^2 - \frac{1}{2}mR^2$

$$= \frac{3}{2}mR^2$$

$$(K.E)_{\text{Rotation}} = \frac{1}{2}I\omega^2 = \frac{1}{2} \cdot \frac{3}{2} \cdot mR^2 \cdot \omega^2 = \frac{3}{4} \cdot \frac{1}{4} \cdot m(2R\omega)^2$$

$$\therefore (K.E)_R = \frac{3}{16}mv^2$$

$$(K.E)_{\text{Translation}} = \frac{1}{2}mv^2$$

$$(K.E)_T = (K.E)_R + (K.E)_T$$

$$= \frac{3}{16}mv^2 + \frac{1}{2}mv^2 = \frac{11}{16}mv^2.$$

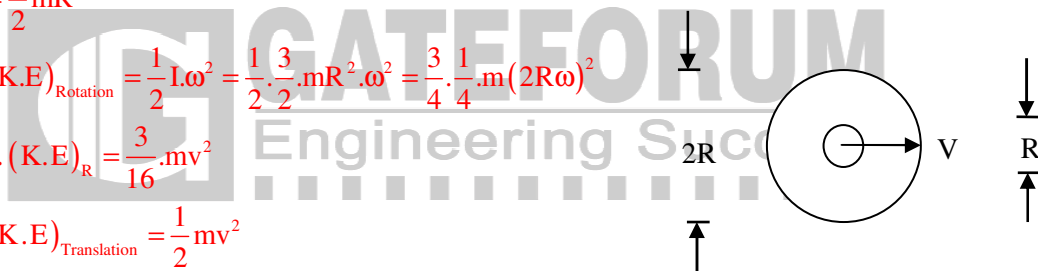

35. A force P is applied at a distance x from the end of the beam as shown in the figure. What would be the value of x so that the displacement at 'A' is equal to zero?

(A) $0.5L$

(B) $0.25L$

(C) $0.33L$

(D) $0.66L$

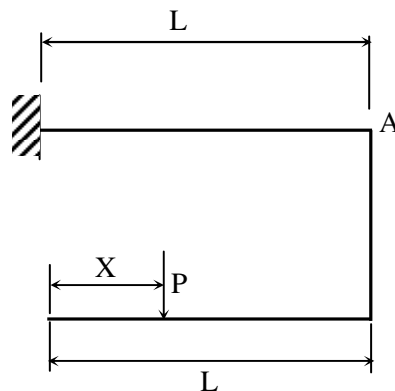

Answer: (C)

Exp:

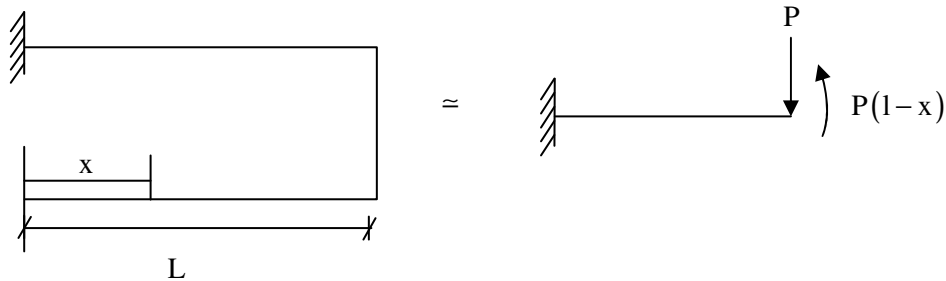

$$\delta_1 = \frac{Pl^3}{3EI} \text{ due to point load (downward)}$$

$$\delta_2 = \frac{ML^2}{2EI} \text{ due to moment (upward)}$$

$$\Rightarrow \delta = \delta_1 - \delta_2 = \frac{Pl^3}{3EI} - \frac{P(1-x)l^2}{2EI} = 0$$

$$\Rightarrow \frac{Pl^3}{3EI} - \frac{Pl^3}{2EI} + \frac{P \times l^2 x}{2EI} = 0$$

$$\Rightarrow \left[\frac{-1}{3} - 1 + x \right] \frac{Pl^2}{2EI} = 0$$

$$\Rightarrow x = \frac{1}{3} - 1 = 0.33L$$

36. Consider a rotating disk cam and a translating roller follower with zero offset. Which one of the following pitch curves, parameterized by t , lying in the interval 0 to 2π , is associated with the maximum translation of the follower during one full rotation of the cam rotating about the center at $(x, y) = (0, 0)$?

(A) $x(t) = \cos t, y(t) = \sin t$

(B) $x(t) = \cos t, y(t) = 2 \sin t$

(C) $x(t) = \frac{1}{2} + \cos t, y(t) = 2 \sin t$

(D) $x(t) = \frac{1}{2} + \cos t, y(t) = \sin t$

Answer: (C)

Exp: From all the four options the maximum amplitudes is in point 'C' as $t = 0$.

(A) $(x)_{t=0} = 1, (y)_{t=0} = 0$

(B) $x = 1, y = 0$

(C) $x = \frac{3}{2}, y = 0$

(D) $x = \frac{3}{2}, y = 0$

Option 'C' has maximum net amplitude.

37. A four-wheel vehicle of mass 1000 kg moves uniformly in a straight line with the wheels revolving at 10 rad/s. The wheels are identical, each with a radius of 0.2 m. Then a constant braking torque is applied to all the wheels and the vehicle experiences a uniform deceleration. For the vehicle to stop in 10 s, the braking torque (in N.m) on each wheel is _____

Answer: 9 to 11

Exp:

$$m = 1000 \text{ kg}, \omega = 10 \text{ Rad/sec}, R = 0.2 \text{ m}, t = 10 \text{ sec when } \omega = 0$$

$$\therefore \omega_f = \omega_i - \alpha t$$

$$\therefore 0 = 10 - \alpha \times 10 \quad \therefore \alpha = 1 \text{ rad/sec}^2$$

$$\text{Now } T = I\alpha$$

$$\therefore (T)_{\text{each wheel}} = \left(\frac{1000}{4} \right) \times 0.2^2 \times 1$$

$$\therefore (T)_{\text{each wheel}} = 10 \text{ N-m}$$

38. A slider-crank mechanism with crank radius 60 mm and connecting rod length 240 mm is shown in figure. The crank is rotating with a uniform angular speed of 10 rad/s, counter clockwise. For the given configuration, the speed (in m/s) of the slider is _____

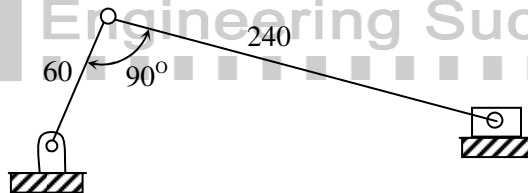

Answer: 0.54 to 0.68

39. Consider an objective function $Z(x_1, x_2) = 3x_1 + 9x_2$ and the constraints

$$x_1 + x_2 \leq 8,$$

$$x_1 + 2x_2 \leq 4,$$

$$x_1 \geq 0, x_2 \geq 0,$$

The maximum value of the objective function is _____

Answer: 17 to 19

Exp: Roots are (12,-4) and (12,-2)

$$\therefore \text{Maximum value of objective function} = 3(12) + 9(-2) = 18.$$

40. A mass-spring-dashpot system with mass $m = 10$ kg, spring constant $k = 6250$ N/m is excited by a harmonic excitation of $10 \cos(25t)$ N. At the steady state, the vibration amplitude of the mass is 40 mm. The damping coefficient (c , in N.s/m) of the dashpot is _____

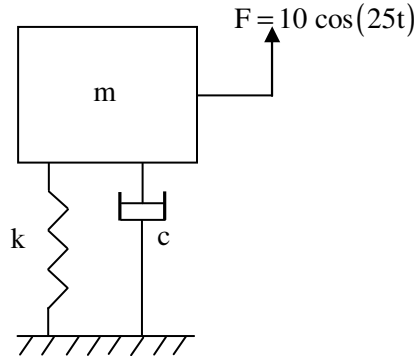

Answer: 9 to 11

Exp:
$$X = \frac{F}{\sqrt{(k - m\omega^2)^2 + (C\omega)^2}}$$

$$= 40\text{mm} = 0.04$$

$$F = 10\text{N}$$

$$\omega = 25$$

$$\Rightarrow 0.04 = \frac{10}{\sqrt{(6250 - 10 \times 25^2)^2 + (C \times 25)^2}}$$

$$C = 10\text{Ns/m}$$

41. A certain amount of an ideal gas is initially at a pressure P_1 and temperature T_1 . First, it undergoes a constant pressure process 1-2 such that $T_2 = 3T_1/4$. Then, it undergoes a constant volume process 2-3 such that $T_3 = T_1/2$. The ratio of the final volume to the initial volume of the ideal gas is

(A) 0.25

(B) 0.75

(C) 1.0

(D) 1.5

Answer: (B)

Exp: For (1-2) process: Constant pressure process $\{P_2 = P_1\}$

$$\frac{T_1}{V_1} = \frac{T_2}{V_2} \Rightarrow V_2 = \frac{T_2}{T_1} \times V_1$$

For (2-3) process: Constant Volume process $\{V_3 = V_2\}$

Given $T_2 = \frac{3T_1}{4}$

$$V_2 = \frac{3T_1}{4T_1} \times V_1 = \frac{3}{4} V_1 \Rightarrow \frac{V_3}{V_1} = \frac{V_2}{V_1} = \frac{3}{4} = 0.75$$

42. An amount of 100 kW of heat is transferred through a wall in steady state. One side of the wall is maintained at 127°C and the other side at 27°C. The entropy generated (in W/K) due to the heat transfer through the wall is _____

Answer: 80 to 85

Exp: $\Delta S_1 = \frac{Q}{T_1}$

$\Delta S_2 = \frac{Q}{T_2}$

$(\Delta S)_{\text{generated}} = \Delta S_1 + \Delta S_2$

$= \frac{Q}{400} - \frac{Q}{300}$

$= \frac{100 \times 10^3}{100} \left(\frac{1}{4} - \frac{1}{3} \right)$

$= 10^3 \times -0.0833$

$= -83.33 \text{ W / K}$

Entropy generated = 83.33 W/K.

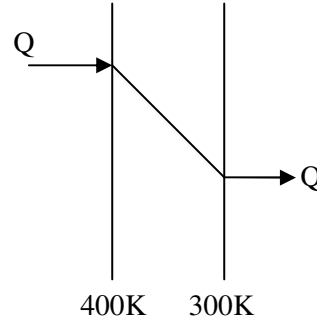

43. A siphon is used to drain water from a large tank as shown in the figure below. Assume that the level of water is maintained constant. Ignore frictional effect due to viscosity and losses at entry and exit. At the exit of the siphon, the velocity of water is _____

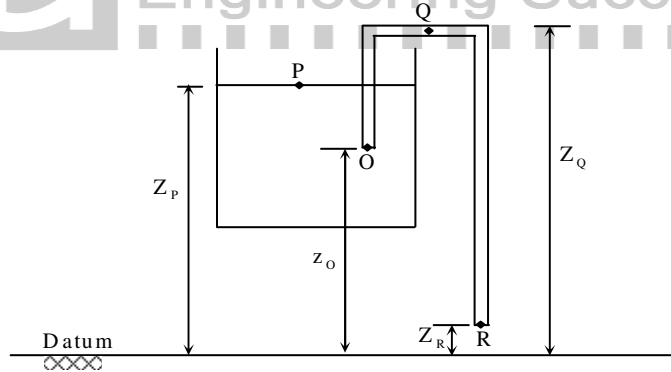

(A) $\sqrt{2g(Z_Q - Z_R)}$

(B) $\sqrt{2g(Z_P - Z_R)}$

(C) $\sqrt{2g(Z_O - Z_R)}$

(D) $\sqrt{2gZ_Q}$

Answer: (B)

Exp: Applying Bernoulli's equation between the points 'P' and 'R'.

$$\frac{P_{\text{atm}}}{\rho g} + \frac{V_P^2}{2g} + Z_P = \frac{P_{\text{atm}}}{\rho g} + \frac{V_R^2}{2g} + Z_R$$

Since the level of liquid in tank remains the same, $V_P = 0$

$\therefore V_R = \sqrt{2g(Z_P - Z_R)}$.

44. Heat transfer through a composite wall is shown in figure. Both the sections of the wall have equal thickness (l). The conductivity of one section is k and that of the other is $2k$. The left face of the wall is at 600 K and the right face is at 300 K. The interface temperature T_i (in K) of the composite wall is _____

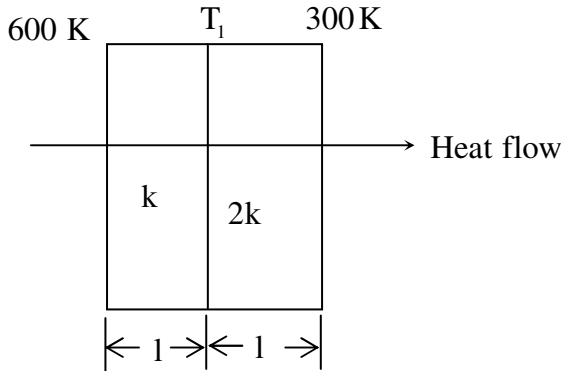

Answer: 399 to 401

Exp: $R = R_1 + R_2$

$$= \frac{L}{KA} + \frac{L}{KA} = \frac{L}{KA} + \frac{L}{2KA} = \frac{3L}{2KA}$$

$$Q = \frac{T_L - T_R}{R}$$

$$= \frac{300}{\frac{3L}{2KA}} = 200 \times \frac{KA}{L} \rightarrow 1$$

At interface

$$Q = \frac{T_L - T_i}{R_i}$$

$$= \frac{600 - T_i}{\frac{L}{KA}} = (600 - T_i) \frac{KA}{L} \rightarrow 2$$

Equating 1 and 2

$$200 \frac{KA}{L} = (600 - T_i) \frac{KA}{L}$$

$$200 = 600 - T_i$$

$$T_i = 400K$$

45. A fluid of dynamic viscosity 2×10^{-5} kg/m.s and density 1 kg/m^3 flows with an average velocity of 1 m/s through a long duct of rectangular ($25 \text{ mm} \times 15 \text{ mm}$) cross-section. Assuming laminar flow, the pressure drop (in Pa) in the fully developed region per meter length of the duct is _____

Answer: 1.7 to 2.0

Exp: Given,

$$\mu = 2 \times 10^{-5} \text{ kg/m.s}, \rho = 1 \text{ kg/m}^3, u_{av} = 1 \text{ m/sec}$$

$$\text{Duct area} = 25 \text{ mm} \times 15 \text{ mm}$$

$$\therefore \frac{\Delta P}{L} = \frac{4 \times \lambda \times \rho \times U_{av}^2}{2 \times D_n} \text{ --- (1)}$$

here λ = Friction factor

$$D_n = \text{Dia}$$

$$\therefore D_n = \frac{4 \times A}{P} \text{ (A = Area, P = parameter)}$$

$$\lambda = \frac{4 \times 25 \times 15}{2(25 + 15)} = 18.75 \text{ mm} \text{ --- (2)}$$

$$\lambda = \frac{16}{\text{Re}} \therefore \text{Re} = \frac{\rho \cdot u_{av} \cdot D_n}{\mu}$$

$$\therefore \text{Re} = \frac{1 \times 1 \times 18.75 \times 10^{-3}}{2 \times 10^{-5}} = 937.5$$

$$\therefore \lambda = \frac{16}{937.5} = 1.707 \times 10^{-2} \text{ --- (3)}$$

Here from equation (3)

$$\frac{\Delta P}{L} = \frac{4 \times 1.707 \times 10^{-2} \times (1)^2 \times 2}{2 \times 18.75 \times 10^{-3}} = 1.8208 \text{ pa/m.}$$

46. At the inlet of an axial impulse turbine rotor, the blade linear speed is 25 m/s, the magnitude of absolute velocity is 100 m/s and the angle between them is 25°. The relative velocity and the axial component of velocity remain the same between the inlet and outlet of the blades. The blade inlet and outlet velocity triangles are shown in the figure. Assuming no losses, the specific work (in J/kg) is _____

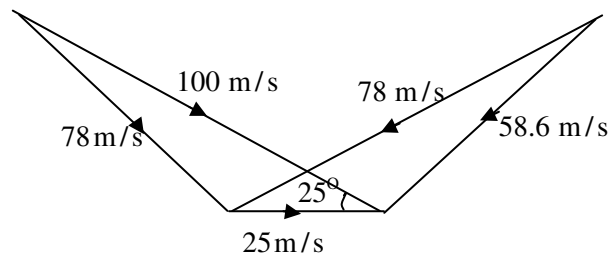

Answer: 3250 to 3300

Exp:

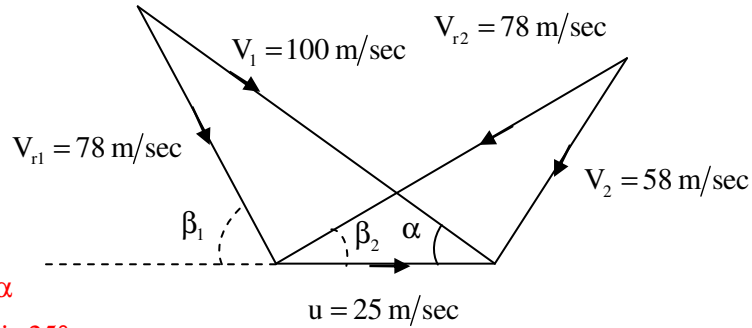

Given $\alpha = 25^\circ$

$$V_{r1} \sin \beta_1 = V_1 \sin \alpha$$

$$\therefore 78 \sin \beta_1 = 100 \sin 25^\circ$$

$$\therefore \beta_1 = 32.81^\circ$$

$$\therefore V_{r1} = V_{r2} \quad \therefore \beta_1 = \beta_2 = 32.81^\circ$$

$$\text{now } \Delta V_w = V_{r1} \cos \beta_1 + V_{r2} \cos \beta_2 = 2V_{r1} \cos \beta_1 = 2 \times 78 \times \cos 32.81^\circ$$

$$\therefore \Delta V_w = 131.1136 \text{ m/sec}$$

$$\therefore \text{Sp. power} = \Delta V_w \cdot u = 131.1136 \times 25 = 3277.84 \text{ J/kg.}$$

47. A solid sphere of radius $r_1 = 20 \text{ mm}$ is placed concentrically inside a hollow sphere of radius $r_2 = 30 \text{ mm}$ as shown in the figure.

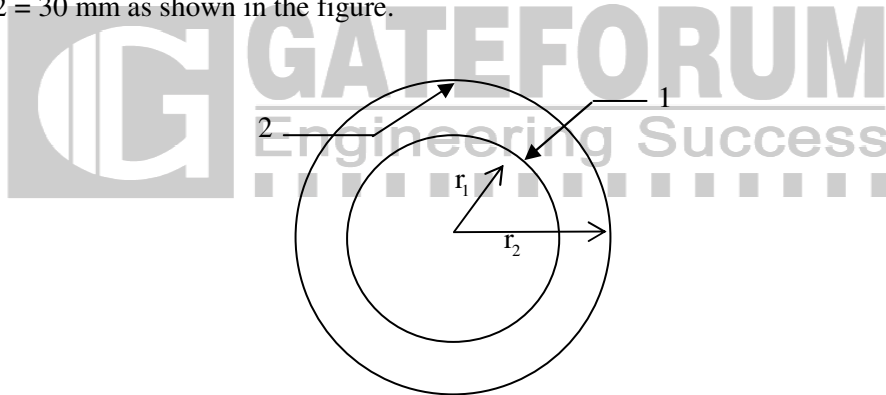

The view factor F_{21} for radiation heat transfer is

(A) $\frac{2}{3}$

(B) $\frac{4}{9}$

(C) $\frac{8}{27}$

(D) $\frac{9}{4}$

Answer: (B)

Exp: $F_{11} + F_{12} = 1$, here $F_{11} = 0$

$$\therefore F_{12} = 1$$

now from Reciprocating law

$$A_1 F_{12} = A_2 F_{21}$$

$$\therefore 2\pi(20)^2 \times 1 = 2\pi(30)^2 \times F_{21} \Rightarrow \therefore F_{21} = \left(\frac{20}{30}\right)^2 = \frac{4}{9}$$

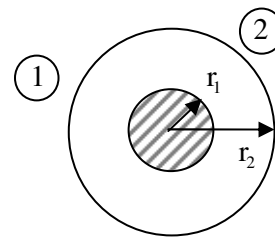

48. A double-pipe counter-flow heat exchanger transfers heat between two water streams. Tube side water at 19 liter/s is heated from 10°C to 38°C. Shell side water at 25 liter/s is entering at 46°C. Assume constant properties of water, density is 1000 kg/m³ and specific heat is 4186 J/kg K. The LMTD (in °C) is _____

Answer: 10.8 to 11.2

Exp: Given: $\dot{m}_h = 25 \text{ L/S}$; $T_{h,i} = 46^\circ\text{C}$, $T_{h,o} = ?$

$$\dot{m}_c = 19 \text{ L/S}; T_{c,i} = 10^\circ\text{C}, T_{c,o} = 38^\circ\text{C}$$

$$\rho = 1000 \text{ kg/m}^3, C = 4186 \text{ J/kg.k}$$

Energy balance

$$\dot{m}_c C (T_{c,o} - T_{c,i}) = \dot{m}_h C (T_{h,i} - T_{h,o})$$

$$19(38 - 10) = 25(46 - T_{h,o})$$

$$T_{h,o} = 24.72^\circ\text{C}$$

$$\text{LMTD} = \frac{\theta_1 - \theta_2}{\ln \theta_1 / \theta_2}$$

$$\theta_1 = T_{h,i} - T_{c,o} = 46 - 38 = 8^\circ\text{C}$$

$$\theta_2 = T_{h,o} - T_{c,i} = 24.72 - 10 = 14.72$$

$$\text{LMTD} = \frac{8 - 14.72}{\ln(8/14.72)} = 11.0206^\circ\text{C}$$

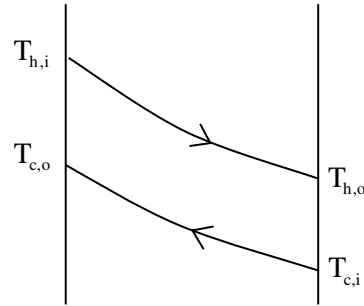

49. A diesel engine has a compression ratio of 17 and cut-off take place at 10% of the stroke. Assuming ratio of specific heats (γ) as 1.4, the air-standard efficiency (in percent) is _____

Answer: 58 to 62

Exp: Compression ratio = 17 = $\frac{V_1}{V_2} = V_1 = 17V_2$

$$\text{where } \rho = \text{cut of ratio} = \frac{V_3}{V_2}$$

$$V_3 - V_2 = \frac{10}{100} V_s$$

$$V_3 - V_2 = 0.1(V_1 - V_2) = 0.1(17V_2 - V_2) = 0.1(16V_2)$$

$$V_3 = 1.6V_2 + V_2$$

$$V_3 = 2.6V_2$$

$$\frac{V_3}{V_2} = \rho = 2.6$$

$$\eta = 1 - \frac{1}{r(r)^{\gamma-1}} \left[\frac{\rho^\gamma - 1}{\rho - 1} \right]$$

$$= 1 - \frac{1}{1.4(17)^{1.4-1}} \times \left[\frac{2.6^{1.4} - 1}{2.6 - 1} \right] = 0.5960 = 59.60\%$$

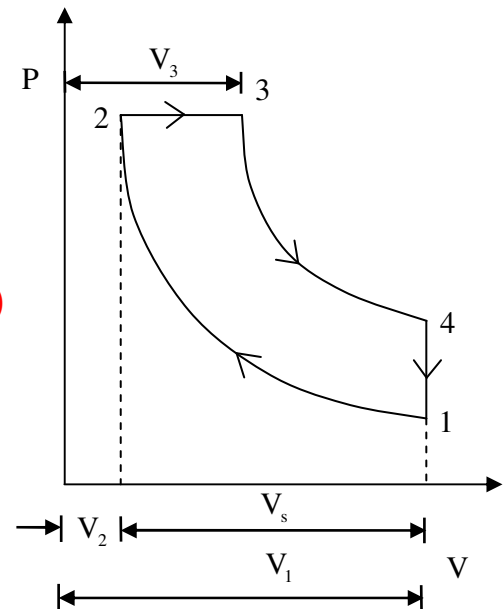

50. Consider the given project network, where numbers along various activities represent the normal time. The free float on activity 4-6 and the project duration, respectively, are

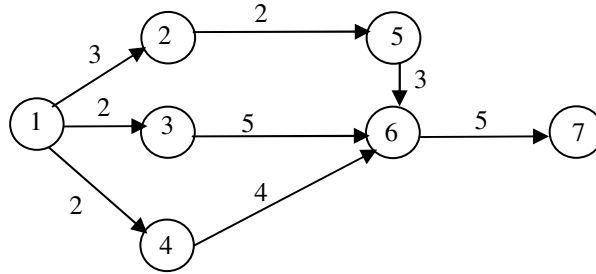

- (A) 2, 13 (B) 0, 13 (C) -2, 13 (D) 2, 12

Answer: (A)

Exp:

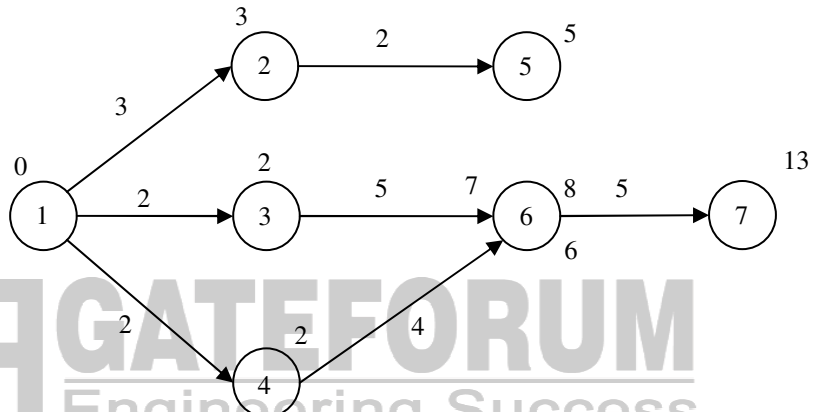

For 4-6

$$F.F = (E_5 - E_i) - T_{is} = (8 - 2) - 4 = 2$$

∴ 2, 13.

51. A manufacturer can produce 12000 bearings per day. The manufacturer received an order of 8000 bearings per day from a customer. The cost of holding a bearing in stock is Rs.0.20 per month. Setup cost per production run is Rs.500. Assuming 300 working days in a year, the frequency of production run should be

- (A) 4.5 days (B) 4.5 months (C) 6.8 days (D) 6.8 months

Answer: (C)

52. A cylindrical blind riser with diameter d and height h , is placed on the top of the mold cavity as shown in the figure. If the riser is of constant volume, then the rate of solidification in the riser is the least when the ratio h/d is

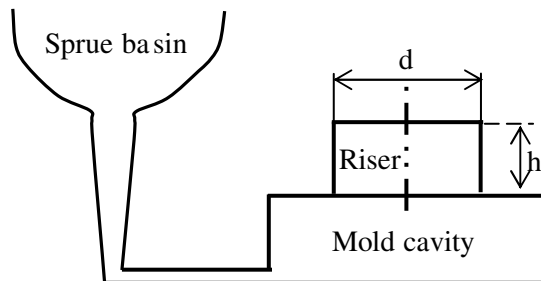

- (A) 1:2 (B) 2:1 (C) 1:4 (D) 4:1

Answer: (A)

Exp: $v = \frac{\pi}{4} D^2 h$

$$h = \frac{4v}{\pi D^2} \text{ --- (1)}$$

$$A_s = \pi D h + \frac{\pi}{4} D^2 = \pi D \frac{4v}{\pi D^2} + \frac{\pi}{4} D^2 = \frac{4v}{D} + \frac{\pi}{4} D^2$$

For min A_s

$$\frac{dA_s}{dD} = 0$$

$$-\frac{4v}{D^2} + \frac{\pi}{4} 2D = 0 \Rightarrow \frac{4v}{D^2} = \frac{d\pi}{2}$$

$$v = \frac{\pi D^3}{8} = \frac{\pi}{4} D^2 h$$

$$D = 2h \Rightarrow \frac{h}{D} = \frac{1}{2}$$

$$h : D = 1 : 2.$$

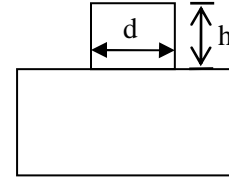

53. The diameter of a recessed ring was measured by using two spherical balls of diameter $d_2 = 60$ mm and $d_1 = 40$ mm as shown in the figure.

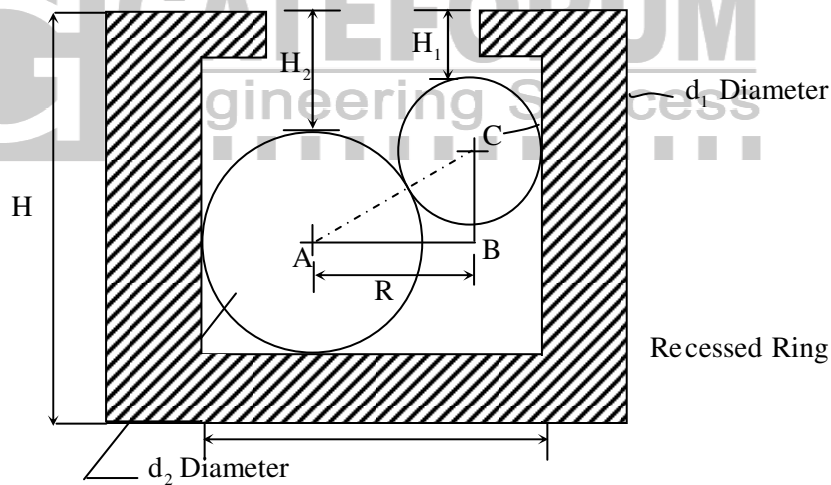

The distance $H_2 = 35.55$ mm and $H_1 = 20.55$ mm. The diameter (D , in mm) of the ring gauge is _____

Answer: 92 to 94

$$\begin{aligned} \text{Exp: } D_{\text{ring}} &= d_1 \sec \frac{\theta}{2} + 2(h_1 + r_1) \tan \frac{\theta}{2} \\ &\therefore \theta = 60^\circ \\ &= 40 \sec 30 + 2(20.55 + 20) \tan 30 \\ D_{\text{ring}} &= 93 \text{ mm.} \end{aligned}$$

54. Which pair of following statements is correct for orthogonal cutting using a single-point cutting tool?
- P. Reduction in friction angle increases cutting force
 Reduction in friction angle decreases cutting force
- R. Reduction in friction angle increases chip thickness
- S. Reduction in friction angle decreases chip thickness
- (A) P and R (B) P and S (C) Q and R (D) Q and S

Answer: (D)

55. For spot welding of two steel sheets (base metal) each of 3 mm thickness, welding current of 10000 A is applied for 0.2s. The heat dissipated to the base metal is 1000 J. Assuming that the heat required for melting 1 mm³ volume of steel is 20 J and interfacial contact resistance between sheets is 0.0002 Ω , the volume (in mm³) of weld nugget is _____

Answer: 140 to 160

Exp. $I^2 RZ = p \times \text{volume of nugget} \times \frac{H.R}{g}$

$$10000^2 \times 0.0002 \times 0.2 = 1 \times \text{volume of nugget} \times \frac{1400}{1000}$$

$$\text{volume of nugget} = 2857.1 \text{ J.mm}^3$$

$$1 \text{ mm}^3 \text{ volume of steel is } 20 \text{ J}$$

$$\text{volume of nugget} = \frac{2857.1 \text{ J.mm}^3}{20 \text{ J}} = 142.8 \text{ mm}^3$$